

Smart Valve Positioner

TS800Series

Instruction Manual



Архангельск (8182)63-90-72
Астана (7172)727-132
Астрахань (8512)99-46-04
Барнаул (3852)73-04-60
Белгород (4722)40-23-64
Брянск (4832)59-03-52
Владивосток (423)249-28-31
Волгоград (844)278-03-48
Вологда (8172)26-41-59
Воронеж (473)204-51-73
Екатеринбург (343)384-55-89

Иваново (4932)77-34-06
Ижевск (3412)26-03-58
Иркутск (395)279-98-46
Казань (843)206-01-48
Калининград (4012)72-03-81
Калуга (4842)92-23-67
Кемерово (3842)65-04-62
Киров (8332)68-02-04
Краснодар (861)203-40-90
Красноярск (391)204-63-61
Курск (4712)77-13-04
Липецк (4742)52-20-81

Магнитогорск (3519)55-03-13
Москва (495)268-04-70
Мурманск (8152)59-64-93
Набережные Челны (8552)20-53-41
Нижний Новгород (831)429-08-12
Новокузнецк (3843)20-46-81
Новосибирск (383)227-86-73
Омск (3812)21-46-40
Орел (4862)44-53-42
Оренбург (3532)37-68-04
Пенза (8412)22-31-16

Пермь (342)205-81-47
Ростов-на-Дону (863)308-18-15
Рязань (4912)46-61-64
Самара (846)206-03-16
Санкт-Петербург (812)309-46-40
Саратов (845)249-38-78
Севастополь (8692)22-31-93
Симферополь (3652)67-13-56
Смоленск (4812)29-41-54
Сочи (862)225-72-31
Ставрополь (8652)20-65-13

Сургут (3462)77-98-35
Тверь (4822)63-31-35
Томск (3822)98-41-53
Тула (4872)74-02-29
Тюмень (3452)66-21-18
Ульяновск (8422)24-23-59
Уфа (347)229-48-12
Хабаровск (4212)92-98-04
Челябинск (351)202-03-61
Череповец (8202)49-02-64
Ярославль (4852)69-52-93

Киргизия (996)312-96-26-47 Казахстан (772)734-952-31 Таджикистан (992)427-82-92-69

<http://tissin.nt-rt.ru/> || tni@nt-rt.ru

Table of Contents

1	Introduction	4
1.1	General information for the user	4
1.2	Requirement for safety	5
1.3	Basic safety instructions for use in the Ex area	6
1.3.1	Conditions to maintain intrinsic safety (Ex i)	6
1.3.2	Data of Intrinsic safety explosion	6
2	Description of products	7
2.1	Function	7
2.2	Features	7
2.3	Options	7
2.4	Applications	7
2.5	Name plats	8
2.6	Products number	9
2.7	Specifications	10
2.8	Structure	11
2.8.1	External structure	11
2.8.2	Internal structure	12
2.9	System configuration	13
2.1	Principle of operation	13
2.11	Dimension drawings	14
2.11.1	TS800 standard type	14
2.11.2	TS800 with limit switch type	14
2.11.3	TS800 feedback shaft connection	14
3	Installation	15
3.1	Before installation	15
3.2	TS800L installation	15
3.2.1	Notes on installation	15
3.2.2	Effective rotation angle of feedback lever	16
3.2.3	Lever type and dimensions	16
3.2.4	Bracket installation	17
3.2.5	Dimension after installation	17
3.3	TS800R installation	18
3.3.1	TS800R installation examples	18
3.3.1	List of supplied installation parts	18
3.3.3	TS800R installation steps	19
3.4	TS820 Remote type installation	21
3.5	Installation of option modules	22
3.5.1	Installation of Position transmitter module	22

3.5.2	Installation of HART communication module-----	22
3.5.3	Installation of Limit switch modules-----	23
3.5.4	How to adjust limit switch cam -----	24
3.6	How to adjust Auto/Manual switch -----	25
3.7	Orifice installation-----	26
4	Pneumatic connection-----	27
4.1	Condition of air supply-----	27
4.2	Description of air ports-----	27
4.3	Air connection-----	28
4.3.1	TS800L air connection-----	28
4.3.2	TS800R air connection-----	28
5	Electrical connections-----	29
5.1	Terminal description-----	29
5.2	Wiring diagrams-----	30
5.2.1	Power and Feedback signal connections-----	30
5.2.2	Limit switch connection-----	30
5.2.3	Alarm signal connection-----	30
6	Calibration-----	31
6.1	Description of Display-----	32
6.2	Description of Buttons-----	29
6.3	How to perform fast auto calibration -----	33
6.3.1	Steps of auto calibration -----	33
6.4	Software map-----	34
6.5	Description of Main menus-----	35
6.6	Description of Main parameters-----	36
6.7	Description of Submenus-----	37
6.7.1	TUNING -----	37
6.7.2	PARAMETE-----	39
6.7.3	DEVICE P-----	41
6.7.4	INFOMATN-----	44
6.7.5	DIAGNOST-----	45
6.7.6	EMERGNCy-----	48
7	Error code and Troubleshooting -----	49
8	Limited warranty and disclaimer -----	50

1 Introduction

1.1 General information for the user

This instruction includes installation, operation, maintenance, and parts information for Tassin TS800 Valve Positioner. Keep these instructions in a location which is easily accessible to every user and make these instructions available to every new owner of the device.

- Installation, commissioning and maintenance of the product can only be performed by trained specialist personnel who have been authorized by the plant operator to do so.
 - To avoid possible injury to the personnel or damage to valve parts, WARNING, CAUTION and NOTICE must be strictly followed.
 - Before installing or commissioning, be sure to read and thoroughly understand the product manual and operate the product properly.
 - Operators must strictly observe the applicable national regulations with regards to installation, function tests, repairs, and maintenance of electrical products.
 - For additional information or if specific problems occur that are not explained in these instructions, contact the manufacturer.
-

Manual version	PM-TS800EN-8/2017
Software version	V.1.0

1.2 Requirements for safety

This manual contains notices you have to observe in order to ensure your personal safety, as well as to prevent damage to property. These safety instructions are intended to prevent hazardous situations and/or equipment damage. For the safety, it is important to follow the instructions in the manual.

 **WARNING**

Failure to observe the warning may result in serious injuries or death.

 **CAUTION**

Failure to observe this warning may result in damage to the device or personal injury.

 **NOTICE**

Failure to observe the warning may result in damage to the device or may degrade performance.

Safety notes

 **CAUTION**

- Only trained and authorized person should operate the machinery and the equipment.
 - Do not use this positioner out of the range of its specifications as this can cause failure.
 - Do not service or attempt to remove product and machinery/equipment until safety is confirmed.
 - Never handle mechanical equipment or disassemble the device until safety is confirmed.
 - Before loosening the pneumatic lines and valves, turn off the pressure and vent the pneumatic lines.
 - Before reaching into the device or the equipment, switch off the power supply and secure to prevent reactivation.
 - Observe applicable accident prevention and the safety regulations for electrical equipment.
-

1.3 Basic safety instructions for use in the Ex area

To prevent the risk of explosion, observe not only the basic safety instructions in the respective operating instructions for operation in the Ex area, but also the following.



- Observe the applicable safety regulations (also national safety regulations) as well as the general rules of technology for construction and operation.
 - Make sure that the device is suitable for the area of use.
 - Check the positioner's certified and permitted explosion proof range.
 - Close all unnecessary cable glands with lock screws approved for the explosions area.
-

1.3.1 Conditions to maintain intrinsic safety (Ex i)



- Make sure to connect the protection device with type of protection "Intrinsic safety" solely to an intrinsically safe circuit.
 - Observe the specifications for the electrical data on the certificate and in technical data.
-

1.3.2 Data of Intrinsic safety explosion

Explosion regulations	IEC 60079-0:2011 IEC 60079-11:2011				
Explosion proof type	Ex ia IIC T5/T6				
Barrier specifications	Ui	li	Pi	Ci	Li
Main power	30V	100mA	700mW	0.6nF	0.3mH
Feedback signal power	30V	100mA	700mW	0.6nF	0.3mH
Alarm1, Alarm2	30V	100mA	700mW	0.6nF	0.3mH
Limit Switch (Dry contact type)	30V	100mA	700mW	2.2nF	0.3mH
Limit Switch (Proximity type)	16V	25mA	34mW	30nF	50uH

2 Description of products

2.1 Function

Smart valve positioner TS800 series controls the valve stroke in response to an input signal of 4~20mA DC from the control panel, DCS or calibrator.

2.2 Features

- LCD and 4 button local control
- Quick and easy calibration
- PST and alarm function
- Auto/Manual switch included
- Built-in self-diagnostic function
- Modularization of the internal parts
- IP66 / NEMA4X
- Improvement of valve control speed by applying large flow pilot valve
- Strong vibration resistance and impact resistance

2.3 Options

- Position transmitter(4~20mA DC Feedback signal)
- HART communication (Ver. HART 7)
- Limit switch (Mechanical or Proximity type)
- Remote control type (TS820)

2.4 Applications

The TS800 is mounted on a pneumatic control valves and is used for fluid control of industrial parts.

- Oil and gas
- Chemicals
- Power plant
- Paper
- Water treatment
- Pharmaceutical
- Printing and dyeing processing
- Food and beverage
- Other

Smart valve positioner
TS800 Series

2.5 Name plates



<TS800>

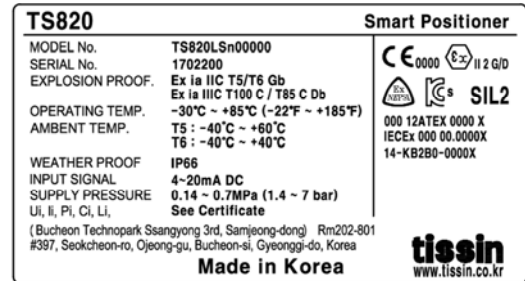

<TS820>

Item	Description
MODEL No.	Indicates the model number.
SERIAL No.	Indicates the serial number.
EXPLOSION PROOF	Indicates the certified explosion proof grade.
OPERATING TEMP.	Indicates the allowable operating temperature.
AMBIENT TEMP.	Indicates the ambient temperature range for the explosion proof. This temperature range must be observed when using in explosion-proof areas.
WEATHER PROOF	Indicates the enclosure grade.
INPUT SIGNAL	Indicates input current signal range.
SUPPLY PRESSURE	Indicates the allowable input supply pressure range.
Ui, Ii, Pi, Ci, Li	Indicates required barrier specification for intrinsically safety circuit configuration. Please refer to the certificate for the detailed specifications.

2.6 Product number

Model	Standard type	TS800						
	Remote type	TS820						
Acting type	Linear type		L					
	Rotary type		R					
Explosion proof type	Non-explosion proof			N				
	Ex ia IIC T5/T6			A				
Connection type	<u>Conduit entry</u>	<u>Air connection</u>						
	G(PF)1/2	PT1/4		1				
	G(PF)1/2	NPT1/4		2				
	NPT1/2	NPT1/4		3				
Lever type (Linear)	10~80mm				1			
	70~150mm				2			
	Adapter type(70mm)				3			
Lever type (Rotary)	M6 x 34L (Fork lever type)				1			
	NAMUR				5			
Ambient Temp.	-30~85℃ (Standard type)					S		
	-40~85℃ (Low temperature type)					L		
Communication*	None						0	
	Position transmitter(4~20mA DC)						1	
	HART						2	
	HART and Position transmitter (4~20mA DC)						3	
Limit switch¹⁾ (TS800)	None							0
	Mechanical type (Dry contact NO, NC, COM)							M
	Proximity type (Open-collector output NPN)							P
	With Dome cover (Without Limit switch)							D
Cable length²⁾ (TS820)	5m							1
	10m							2
	User define(Less than 20 meters)							X

Note

- 1) Only for TS800 model.
2) Only for TS820 model.

2.7 Specifications

Model		TS800L / TS820L	TS800R / TS820R
Input signal		4~20mA DC	
Impedance		500Ω (20mA DC)	
Supply pressure		0.14~0.7MPa	
Stroke		10~150mm	0~90°
Air connection		PT1/4, NPT1/4	
Gauge connection		PT1/8, NPT1/8	
Conduit		G(PF)1/2, NPT1/2	
Explosion proof type		Ex ia IIC T5/T6	
Degree of protection		IP66	
Ambient Temp.	Acting Temp.	-30℃ ~ 85℃ (Standard type), -40℃ ~ 85℃ (Low temp type)	
	Explosion Temp.	-40℃ ~ 60℃ (T5) / -40℃ ~ 40℃ (T6)	
Linearity		±0.5% F.S.	
Sensitivity		±0.2% F.S.	
Hysteresis		±0.5% F.S.	
Repeatability		±0.3% F.S.	
Air consumption		Below 2.3LPM (Sup.=0.14MPa)	
Required air quality		Class 3 (ISO8573-1)	
Flow capacity		Over 100LPM (Sup.=0.14MPa)	
Material		Aluminum die cast	
Weight		2.2kg	

Option specifications

Options	Item	Specification
HART	HART version	HART 7
Position transmitter	Wire connection type	2Wire
	Supply voltage	10~30V DC
Limit switch	Mechanical type	AC125V 3A, DC30V,2A
	Proximity type	DC8.2V 8.2A

Note: Please contact our sales department for other specifications.

2.8 Structure

2.8.1 External structure

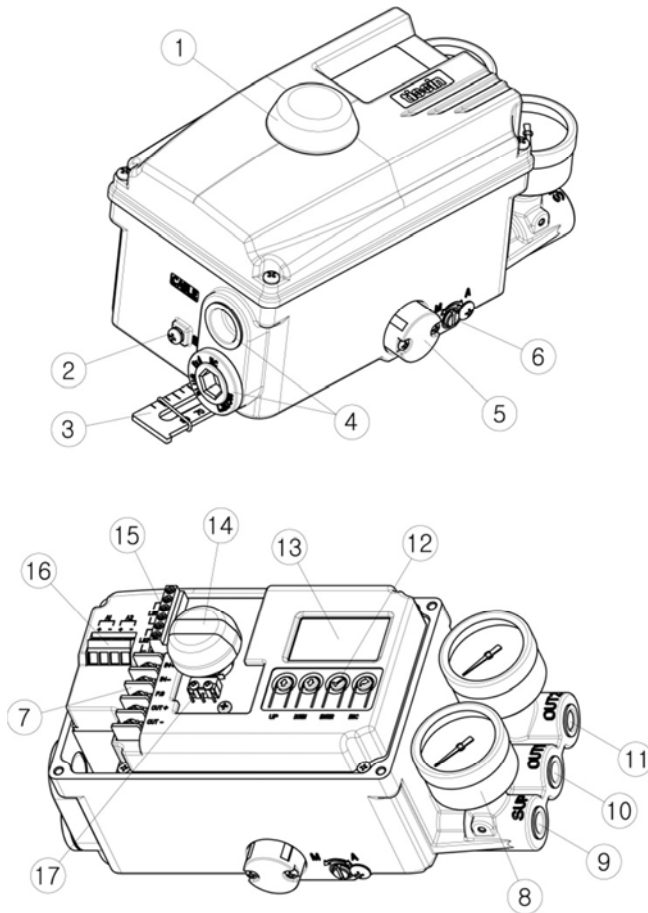

- ① Dome cover
- ② External ground
- ③ Feedback lever
- ④ Conduit
- ⑤ Air vent hole cover
- ⑥ Auto/Manual switch
- ⑦ Terminal block
- ⑧ Pressure gauge
- ⑨ Air supply port
- ⑩ OUT1 port
- ⑪ OUT2 port
- ⑫ Button
- ⑬ LCD
- ⑭ Dome indicator
- ⑮ Limit switch connection terminal
- ⑯ Alarm connection terminal
- ⑰ Limit switch

Note: Only the limit switch type product is equipped with a dome indicator.

2.8.2 Internal structure

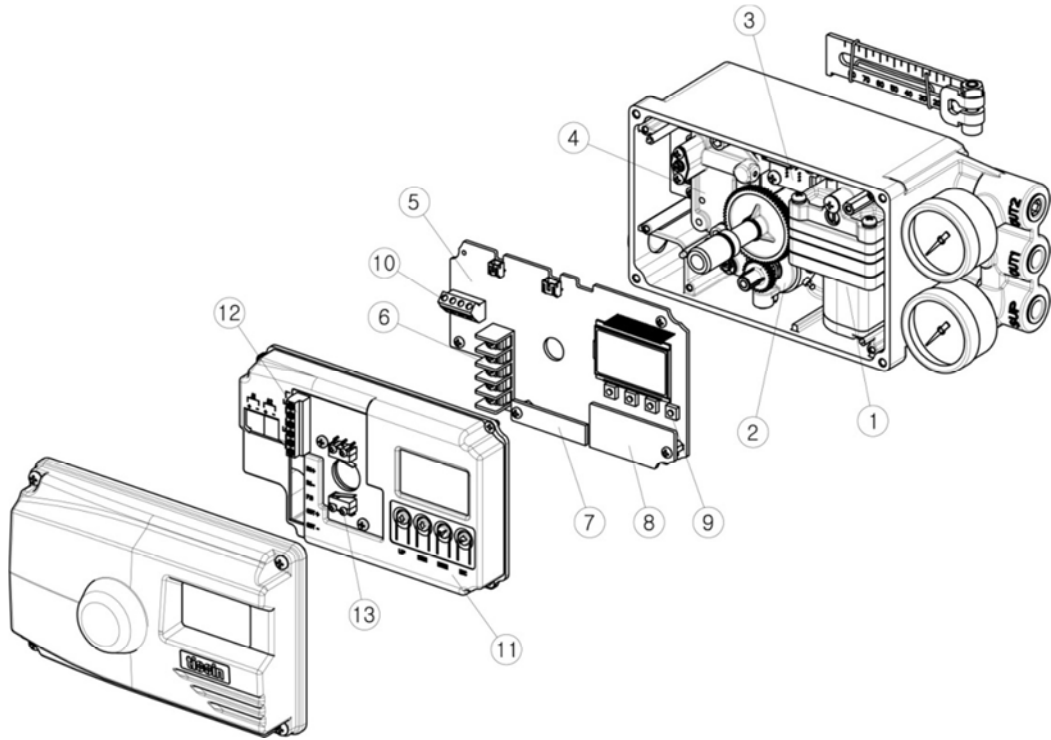

-
- | | |
|--------------------------------------|---|
| ① Pilot valve | ⑧ Position transmitter module(Optional) |
| ② Potentiometer | ⑨ Buttons |
| ③ Pressure sensor (Option) | ⑩ Alarm signal connection terminal |
| ④ Torque motor | ⑪ PCB cover |
| ⑤ Main PCB | ⑫ Limit switch connection terminal |
| ⑥ Terminal block | ⑬ Limit switch (Option) |
| ⑦ HART communication module (Option) | |
-

2.9 System configuration

Basically, the control valve system consists of a positioner for controlling the pneumatic pressure of the actuator, an actuator for controlling the opening of the valve, and a valve for controlling the flow of the fluid.

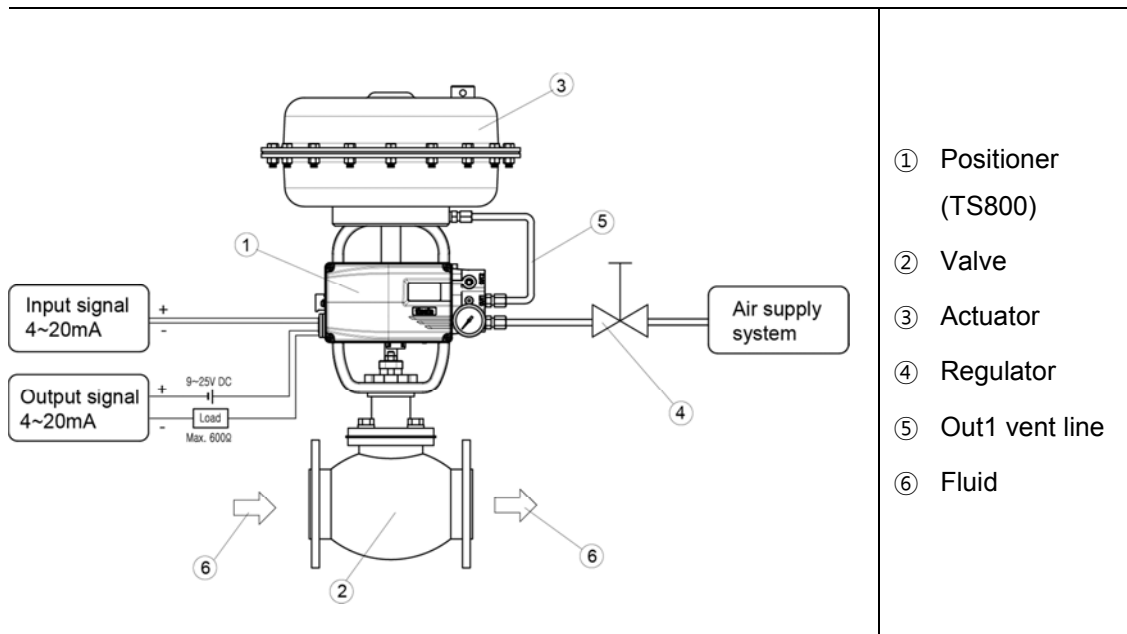

2.10 Principle of operation

TS800 receives the 4-20mA input signal of the control room, the micro-processor (CPU) compares input signal with position feedback through the potentiometer and sends control signal to the I/P conversion module torque motor, torque motor converts it to a pneumatic signal to control the pilot valve to control the opening of the control valve by converting the output pressure of OUT1 and OUT2.

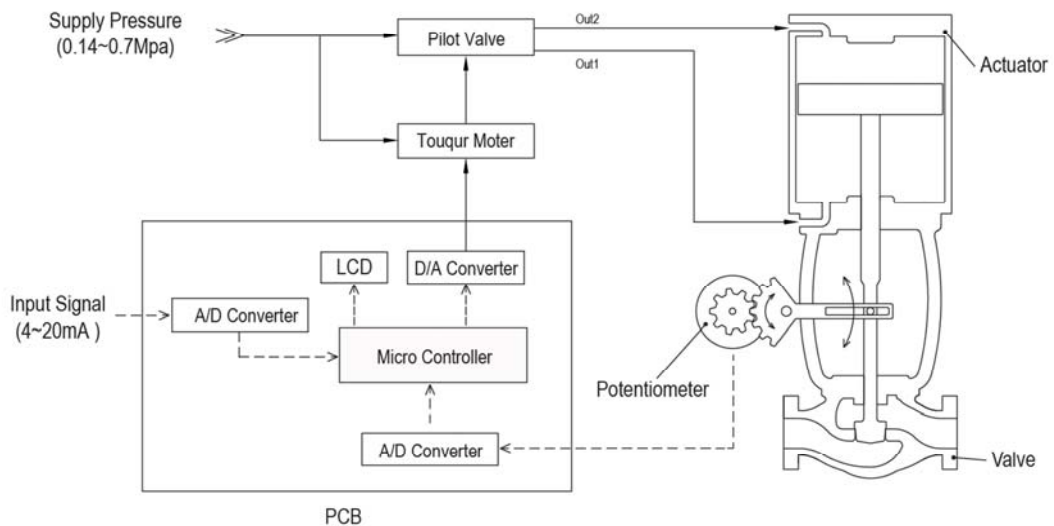

2.11 Dimension drawings

2.11.1 TS800 standard type

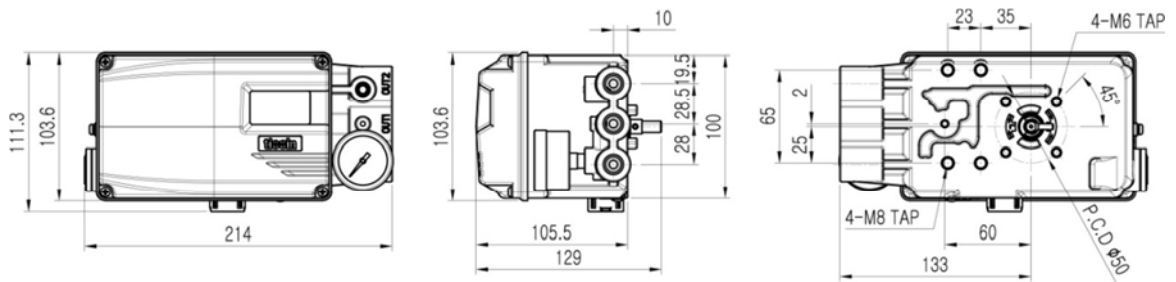

2.11.2 TS800 with limit switch type

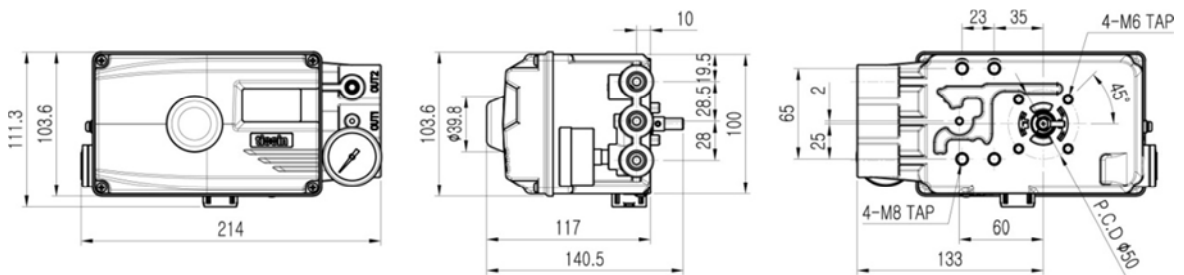

2.11.3 TS800 feedback shaft connection

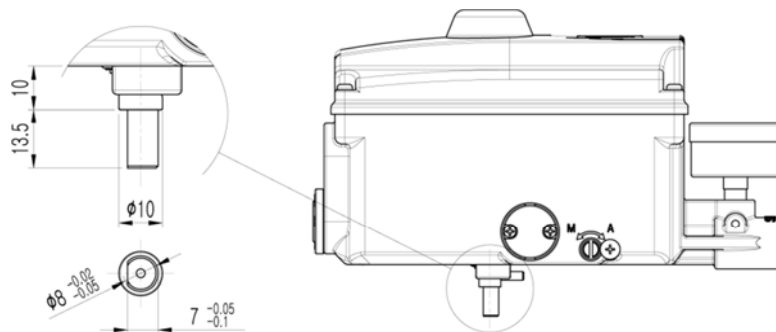

3 Installation

3.1 Before installation

 **WARNING**

- Make sure if TS800 is appropriate to the valve and actuator installation conditions and the site requirements specifications before installation.
 - If the installation state is not correct, TS800 control characteristics may be degraded.
-

3.2 TS800L installation

3.2.1 Notes on installation

When make the mounting bracket and connecting the lever to the stem connection pin, be sure to observe the following two points.

If not compliance will affect the product performance such as linearity.

 **NOTICE**

- ① When the valve stroke is 50%, the feedback lever should be horizontal.
 - ② When the valve stroke is 50%, the stem connection pin must be located at the numeric position marked on the feedback lever that is corresponding to the valve stroke.
-

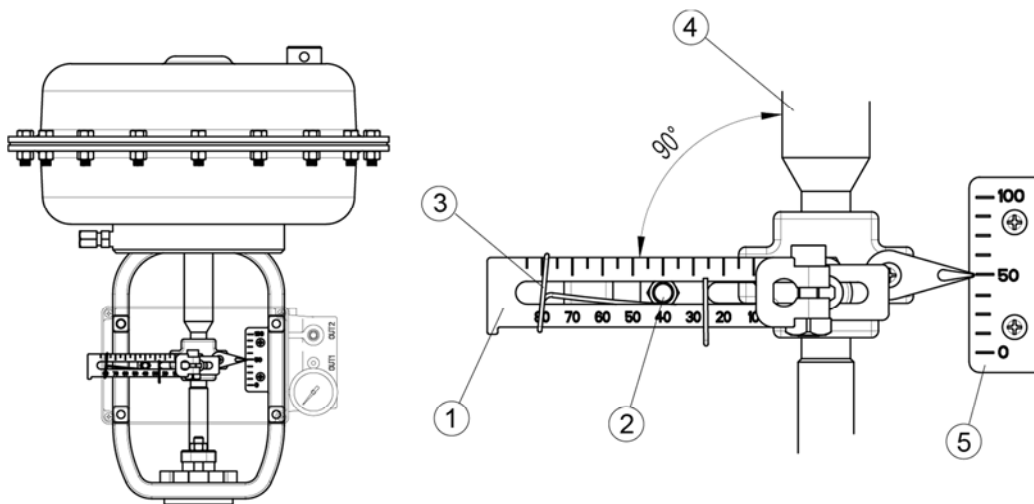

-
- | | |
|-----------------------|---------------------------|
| ① Feedback lever | ④ Actuator stem |
| ② Stem connection pin | ⑤ Valve opening indicator |
| ③ Pin fixing spring | |
-

3.2.2 Effective rotation angle range of the feedback lever

The effective rotation angle of TS800L lever is respectively 30° upward and downward that is based on horizon.

Follow 3.2.1notes, effective rotation angle can be maintained to achieve the best performance.

⚠ NOTICE

- If the rotation angle range is too small during operation, the performance of products such as linearity may be degradation.
- If the rotation angle range is too big during operation, may damage the product or cause malfunctions.

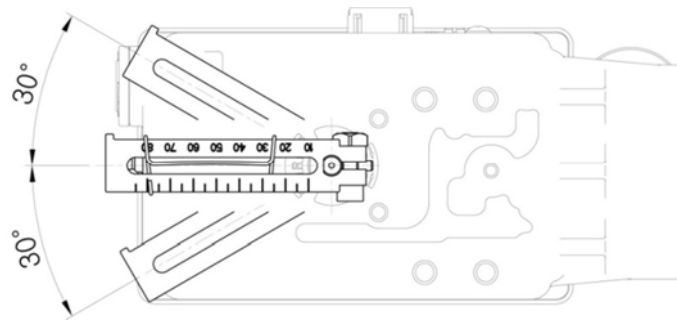

3.2.3 Lever type and dimensions

The numeric position marked on the feedback lever correspond to the valve stroke, and the stem connection pin must be connected to the corresponding marked location

Lever No.	Valve stroke	Dimensions
No.1	10~80mm	<p>Technical drawing of lever No.1. It features a scale from 0 to 80. The total length of the lever is 73.61 mm. The end of the lever has a rounded tip with a radius of R3.25.</p>
No.2	70~150mm	<p>Technical drawing of lever No.2. It features a scale from 0 to 150. The total length of the lever is 138.56 mm. The end of the lever has a rounded tip with a radius of R3.25.</p>
No.3	10~70mm	<p>Technical drawing of lever No.3. It features a scale from 0 to 70. The total length of the lever is 75 mm. The end of the lever has a rounded tip with a radius of R2.</p>

3.2.4 Bracket Installation

Refer to the TS800L drawing (refer to 2.10.2) and actuator drawing, and make appropriate bracket and install the positioner on the actuator.

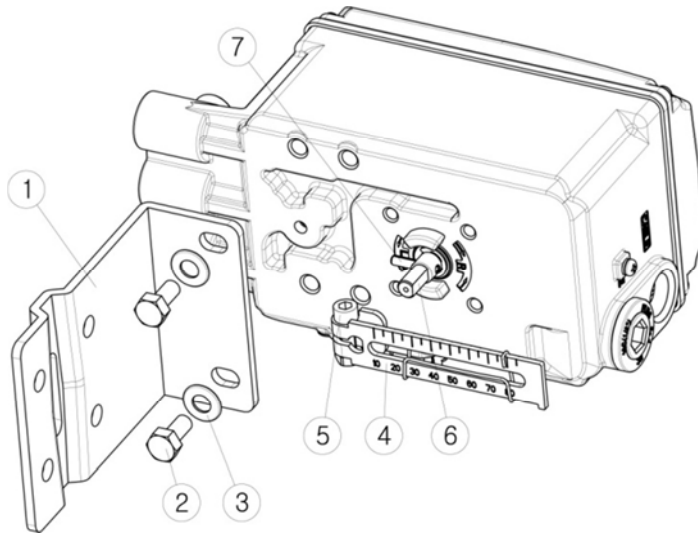

- ① Bracket
- ② Bolt (M8)
- ③ Washer
- ④ Feedback lever
- ⑤ Lever fixing bolt
- ⑥ Main shaft
- ⑦ Shaft fixing pin

3.2.6 Dimension after installation

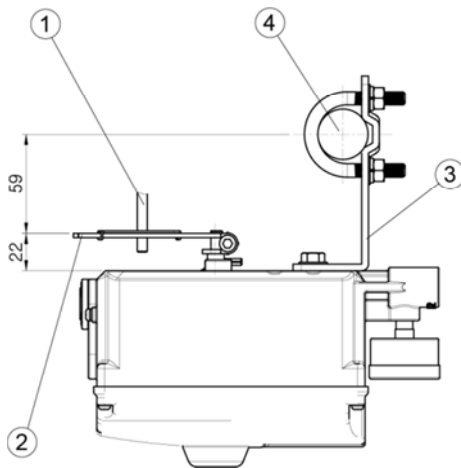

<When the lever is No.1 or 2 >

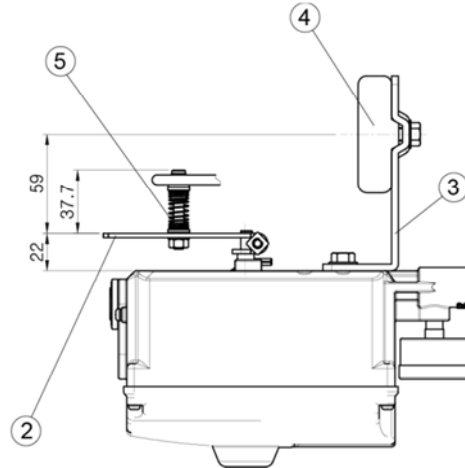

<When the lever is No.3>

- ① Stem connection pin
- ② Feedback lever
- ③ Bracket

- ④ Actuator yolk
- ⑤ Lever adapter

3.3 TS800R installation

3.3.2 TS800R installation examples

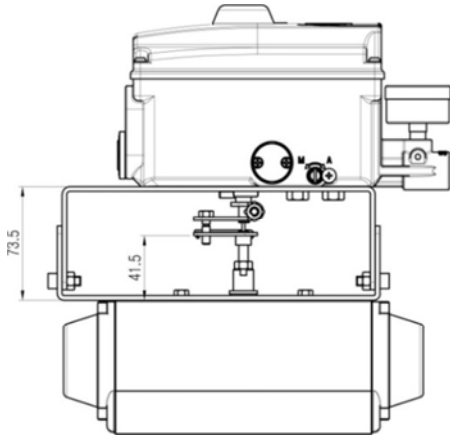

<Fork lever type>

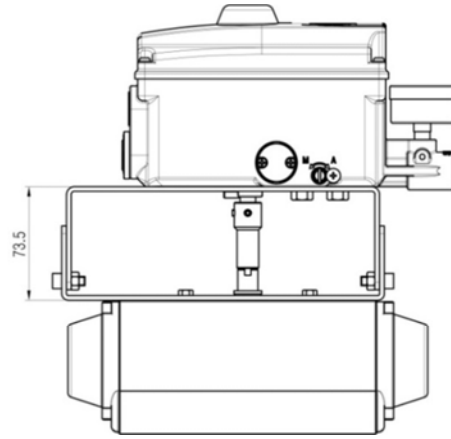

<NAMUR type>

3.3.3 TS800R list of supplied installation parts

When shipped from the factory, parts 1~8 are provided as standard.

The brackets support the NAMUR mounting standard (VDI/VDE3835, IEC60534-6-2).

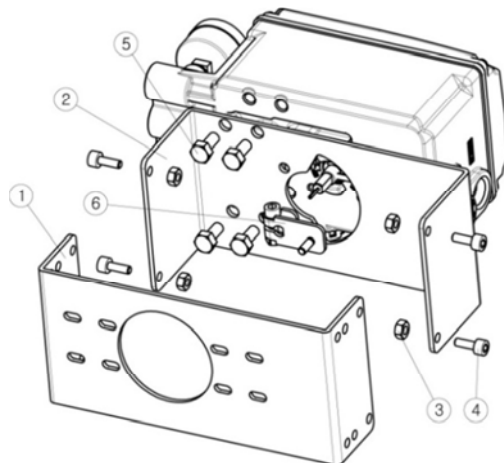

<Fork lever type>

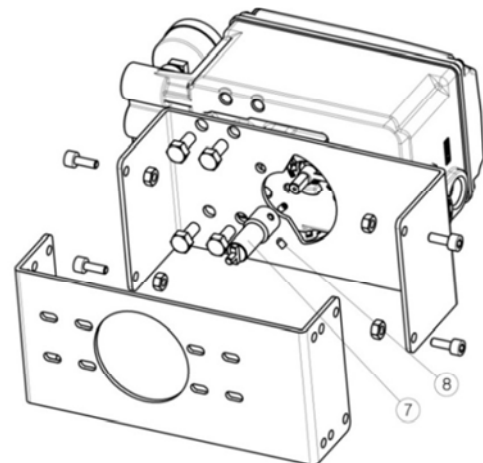



<NAMUR type>

- ① Lower bracket(1)
- ② Upper bracket(1)
- ③ Nuts(4)
- ④ Screws (M6x4)

- ⑤ Screws (M8x4)
- ⑥ Fork lever(1)
- ⑦ NAMUR adapter (1)
- ⑧ Adapter fixing pin(2)

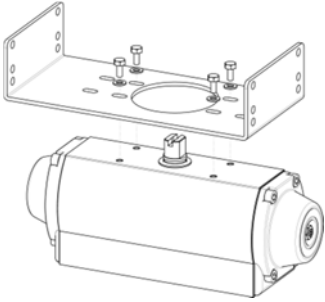
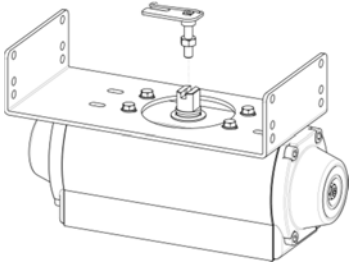
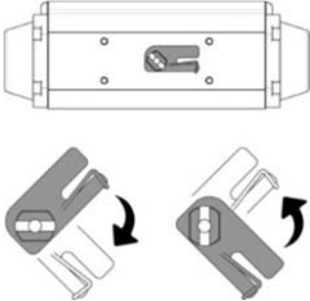
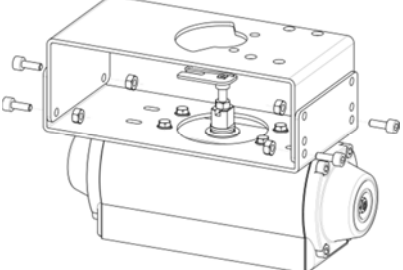
3.3.4 TS800R installation steps

<p>1</p>	<p>Lower bracket installation Attach the lower bracket to the actuator and secure it with the screw.</p>	
<p>2</p>	<p>Fork lever installation Insert the fork lever into the actuator stem and tighten with the fixing bolt.</p>	
<p>2</p>	<p>Position the start point of the fork lever according to the direction of rotation of the actuator stem.</p>	
<p>3</p>	<p>Tighten upper and lower brackets Connect the upper bracket to the lower bracket attached to the actuator and fasten with the screw.</p>	
	<p>Tighten the bolts to the corresponding holes of 20.30 and 50 depending on the actuator stem height.</p>	

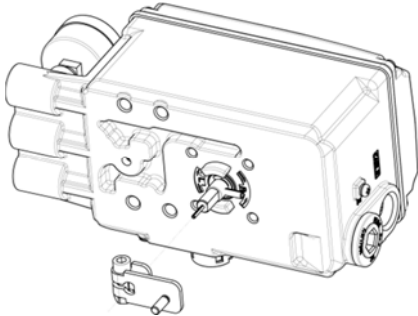
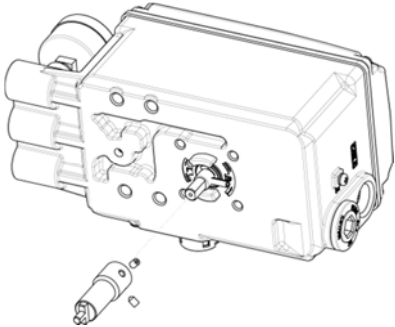
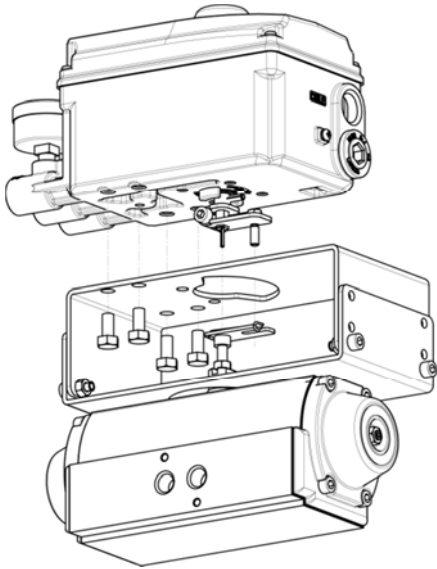
	<p>Shaft lever installation</p> <p>Fork lever type Insert the shaft lever into the main shaft and tighten with the fixing bolt.</p>	
4	<p>NAMR type Insert the NAMUR shaft adapter into main shaft and fix it with two fixing pins.</p>	
5	<p>Attach the positioner to the upper bracket and fix it with screw.</p> <p>At this time, insert the lever pin at the bottom of the fork lever into the hole of the fork lever attached to the actuator and then align the center.</p>	

3.4 TS820 Remote type installation

The TS820 is designed cabled to the sensor part and the main body , It is designed to transmit the change of the stem position of the valve to the body through the potentiometer built in the sensor.

Application site

- Where the valve is located at a high or inaccessible location.
- High temperature environment. (Over than 85°degrees)
- Large vibrating lines.

Installation

- ① Install the sensor in the valve, and install the body in the accessible places.
- ② Please follow the installation instructions of TS800L or TS800R for sensor installation.
- ③ The sensor and the body are connected via cable, the length of cable must not exceed 20M.
- ④ Pneumatic piping should connect the Out port of the main body to the actuator.

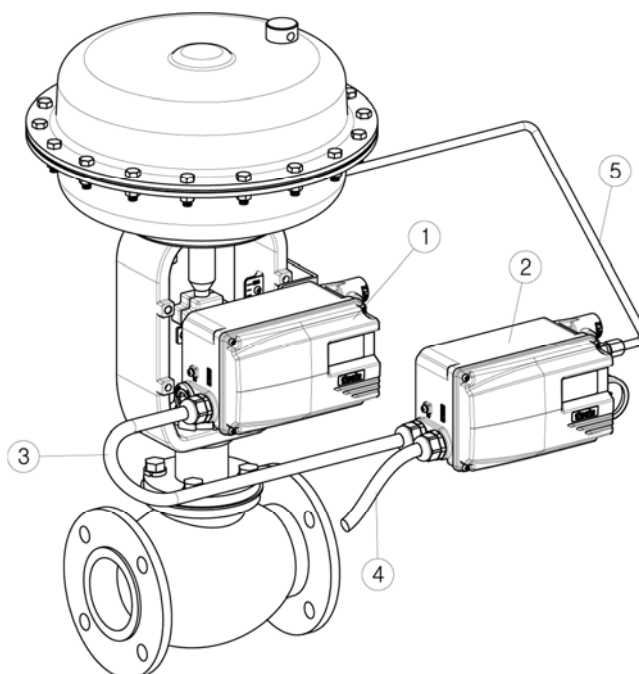

- ① Sensor
- ② Body
- ③ Cable
- ④ Entry power cable
- ⑤ Out1 piping

3.5 Installation of option modules

According to the site requirements , the following modules can be purchased separately and installed. The corresponding function can be realized by installing modules, and the modules do not affect each other.

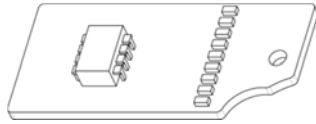

<Position transmitter module>

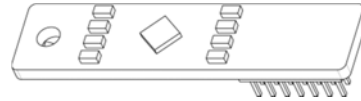

<HART communication module>

3.5.1 Installation of position transmitter module

Open the body cover and PCB cover, and install the position transmitter module to the main PCB as figure below.

⚠ NOTICE

Be sure to have the feedback zero point setting and end point setting once when you after installing the feedback module. Please refer to page 38 OUT ZERO and OUT END setting method.

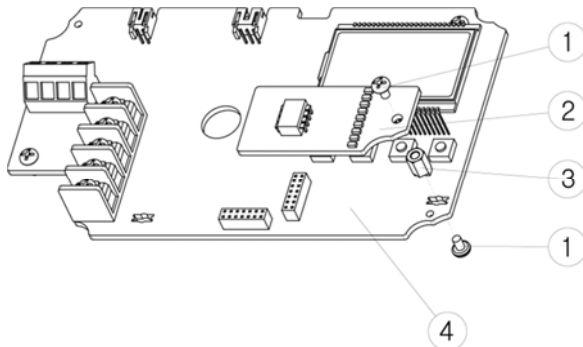

- ① Fixing bolt
- ② Feedback module
- ③ Module bracket
- ④ Main PCB

3.5.2 Installation of HART communication module

Open the body cover and PCB cover, and install the HART communication module to the main PCB as figure below.

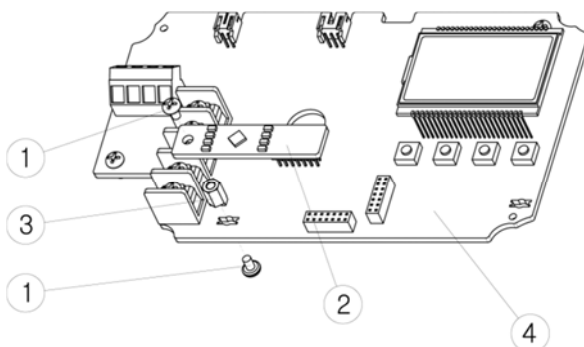

- ① Fixing bolt
- ② HART module
- ③ Module bracket
- ④ Main PCB

3.4.3 Installation of limit switch modules.

There are mechanical and proximity two types of limit switch.

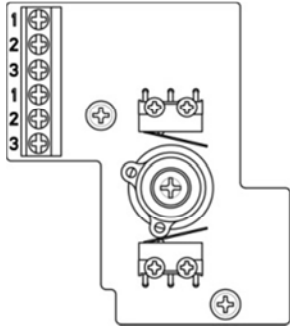

<Mechanical type module>

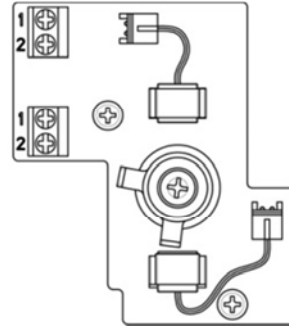

<Proximity type module>

Installation steps

- ① Open the cover.
- ② Mount the limit switch module in the PCB protective cover groove and fix with fixing bolts.
- ③ Turn the camshaft and mount it to the main shaft.
- ④ Fix the camshaft with fixing bolts.
- ⑤ Mount the dome indicator to the camshaft.

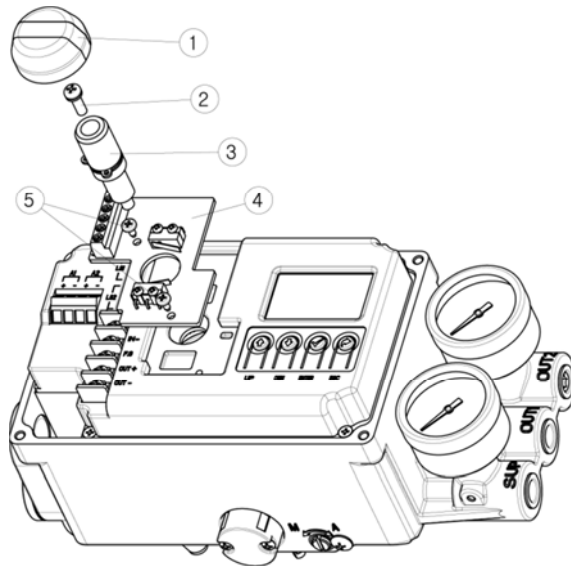

- ① Dome indicator
- ② Bolt
- ③ Camshaft
- ④ Limit switch module
- ⑤ Module fixing bolts

Note

The standard product does not have a dome indicator sight window.
The cover for the limit switch product must also be replaced.

3.4.4 How to adjust limit switch cam

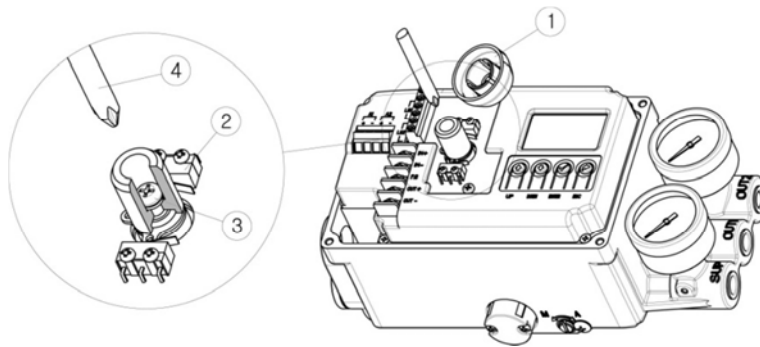

- ① Dome indicator
- ② Switch
- ③ Fixing bolt
- ④ Phillips screwdriver

The cam position has been set at the factory. If you want to change the cam position, please follow the steps below.

- ① Open the cover and separate the dome indicator referring to the above figure.
- ② Loosen the fixing bolt slightly with a Phillips screwdriver, but do not separate it.
- ③ Adjust the com 3 and 4 by referring to the following figure below, and adjust the angle so that the switch operates at the desired position.
- ④ After adjusting the angle, tighten the fixing bolt tightly.

Mechanical switch	Proximity switch
<ul style="list-style-type: none"> ① Micro switch 1 ② Micro switch 2 ③ Operating cam 1 ④ Operating cam 2 ⑤ Fixing screw 	<ul style="list-style-type: none"> ① Proximity switch 1 ② Proximity switch 2 ③ Operating cam1 ④ Operating cam 2 ⑤ Fixing screw

3.6 How to adjust Auto/Manual switch

⚠ WARNING

- Be careful that the valve moves when the Auto/Manual switch is operated.
- Do not exceed the permissible air pressure range since the input air pressure is directly transmitted to the actuator when switching to manual mode.

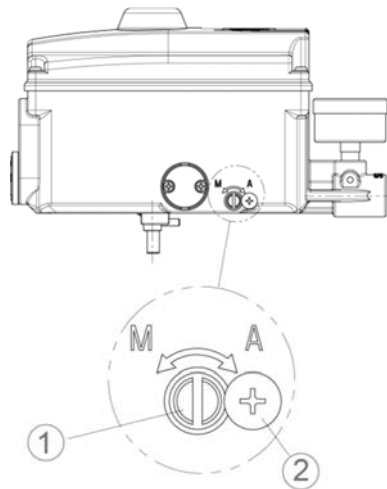

- ① Auto/Manual switch
- ② Lock screw

<p>Description</p>	<p>The Auto/Manual switch acts as a bypass valve.</p> <ul style="list-style-type: none"> • If set the Auto, control valve opening by positioner. • If set to Manual, the supply pressure input from the regulator is transmitted directly to the actuator regardless of the signal from the positioner
<p>Purpose</p>	<ul style="list-style-type: none"> • When the control valve fails, set to Manual mode and adjust the output pressure of the regulator, if the valve moves with the pressure change, there is a high possibility of the problem of the positioner, if the valve does not move, there is a high probability that the valve has failed. • You can adjust the valve opening with the regulator by switching to Manual mode in case of product installation or field emergency
<p>Adjustment method</p>	<ul style="list-style-type: none"> • Turning the Auto/Manual switch fully clockwise with a slotted screwdriver sets the Auto mode, will control the valve with the positioner • Turning the Auto/Manual switch counterclockwise several times with a slotted screwdriver sets the Manual mode, and the regulator's air pressure is transmitted directly to the actuator.
<p>Notes</p>	<ul style="list-style-type: none"> • The product is set to Auto mode at the factory. • Auto/Manual switch works only with single type model.

3.7 Orifice installation

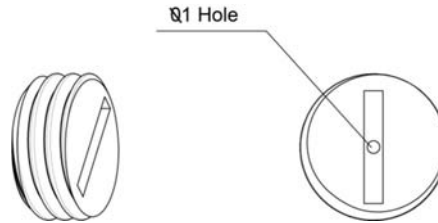

<Orifice>

Purpose

A normal action product does not need to install the orifice, but if the hunting phenomenon occurs after installation on a small actuator, it can be solved by installing an orifice to reduce the output flow of air pressure transmitted to the actuator from the positioner. The hole size of the orifice is 1mm.

How to install

As figure below, Insert the orifice into the OUT1 port, and fix it by turning it all the way with a slotted screwdriver

- When used for single type actuator, you only need to install orifice on OUT1 port
- When using for double type actuator, they must be installed on both OUT1 and OUT2 ports.

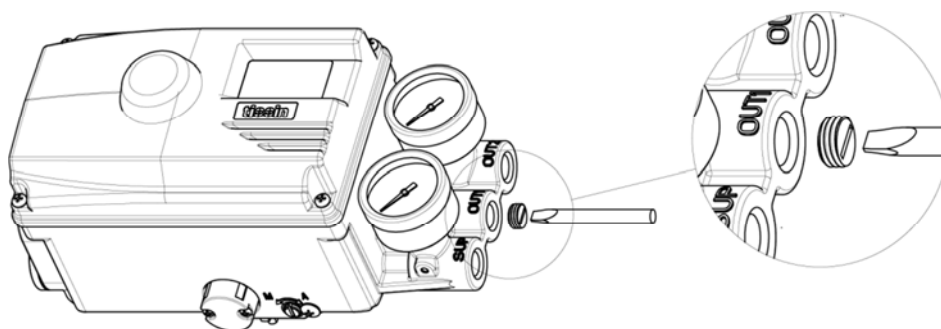

Note

Please contact us, if you need any of the above parts.

4 Pneumatic connection

4.1 Conditions of supply air

 **NOTICE**

- Use only dehumidified and dust extracted compressed clean air.
 - The air pressure input must be equipped with a regulator to supply a constant air pressure.
-

4.2 Description of air ports

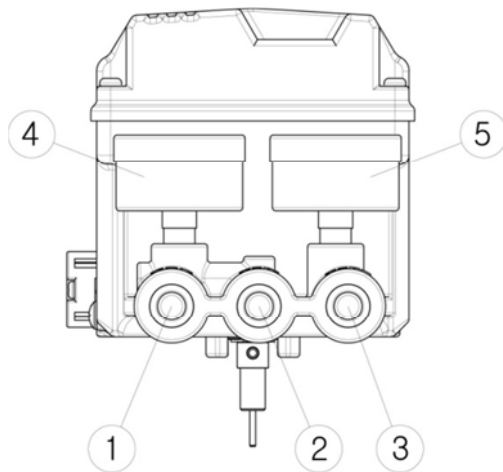

- ① Supply port
- ② OUT1 port
- ③ OUT2 port
- ④ Out1 gauge
- ⑤ Out2 gauge

4.3 Air connections

 **NOTICE**

- This product is designed to increase the air pressure of out1 as the 4 ~ 20mA current input signal increases.

4.3.1 TS800L air connections

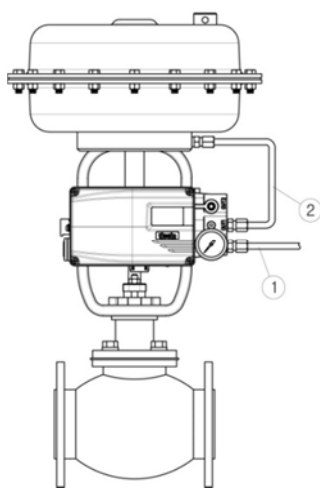

< Piping with single actuator >

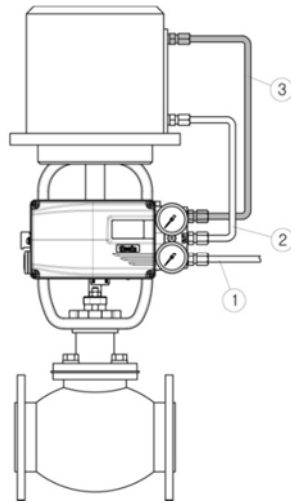

<Piping with double actuator>

- ① Air supply
- ② Out1
- ③ Out2

4.3.2 TS800R air connections

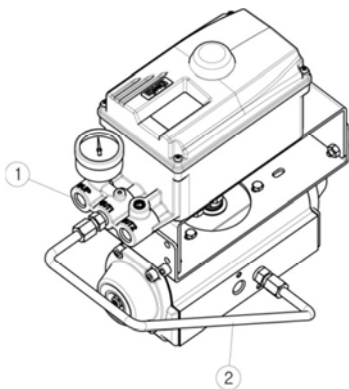

< Piping with single actuator >

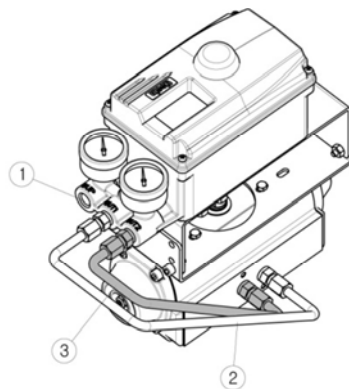

<Piping with double actuator>

- ① Air supply
- ② Out1
- ③ Out2

5 Electrical connections

WARNING

- Be sure to check always that the electrical load is within the stated range on the nameplate. Exceeding the rating might cause a malfunction to circuit boards or burn out electrical components.
- Check polarity of + and – exactly and connect wires.

5.1 Terminal description

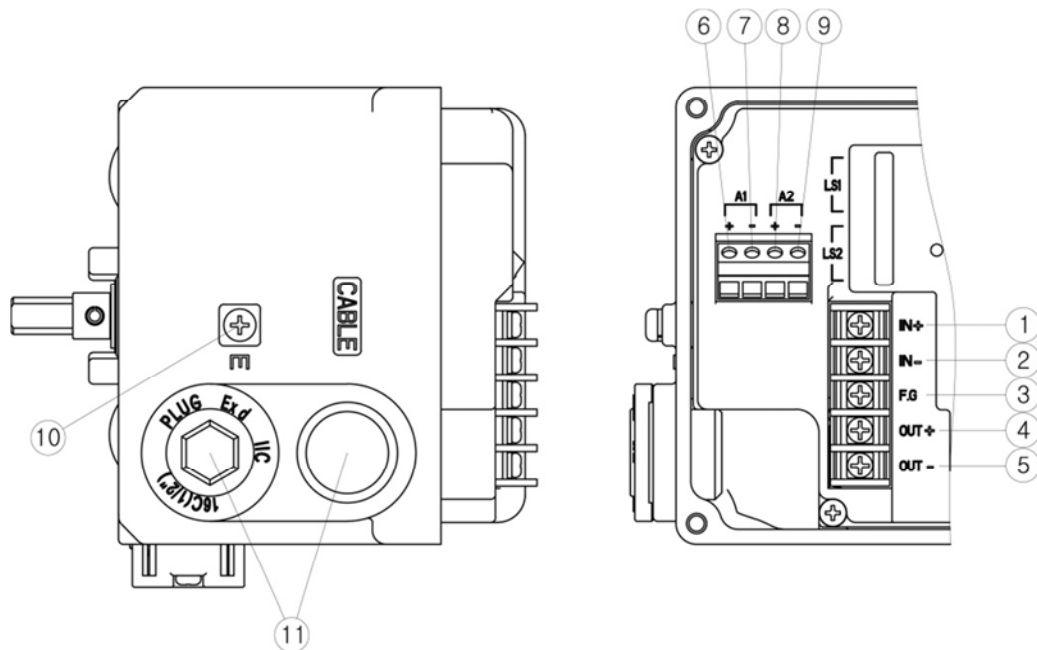

- | | |
|-----------------------|------------------------|
| ① Input signal (+) | ⑥ Alarm1 signal (+) |
| ② Input signal (-) | ⑦ Alarm1 signal (-) |
| ③ Internal ground | ⑧ Alarm2 signal (+) |
| ④ Feedback signal (+) | ⑨ Alarm2 signal (-) |
| ⑤ Feedback signal (-) | ⑩ External ground bolt |
| | ⑪ Conduit |

5.2 Wiring diagrams

5.2.1 Power and feedback signal connection

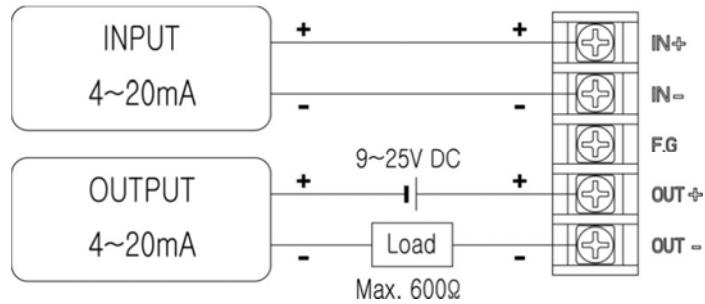

5.2.2 Limit switch connection

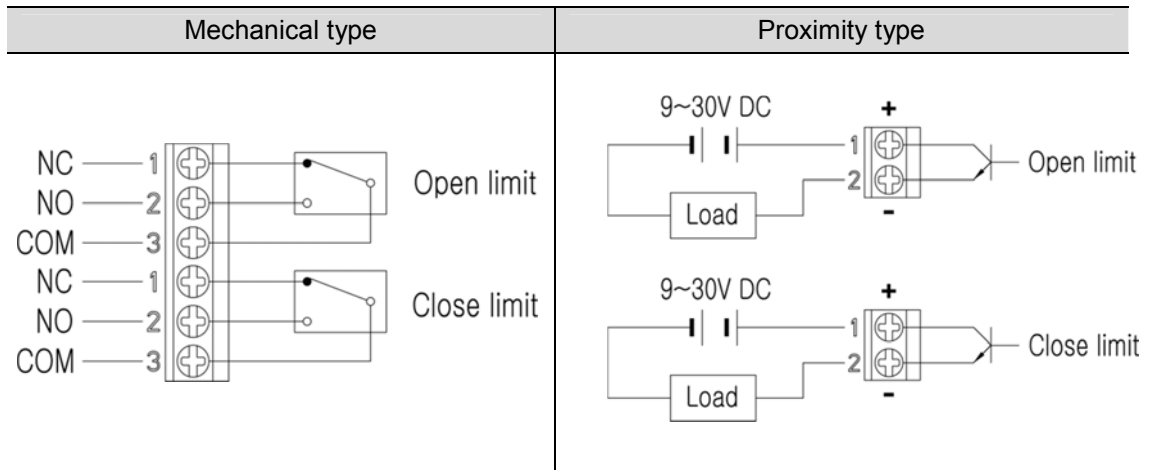

5.2.3 Alarm signal connection

The alarm module is built in to all products. According to the requirements of the site, you can get the feedback from the emergency alarm signal by wiring as follow.

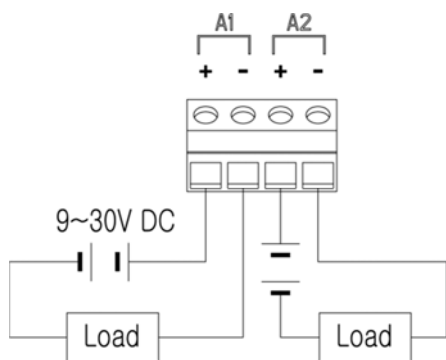

The alarm circuit is OFF when the system is operating normally.

The alarm circuit turns ON according to the set values as below.

- When the product has seriously problems
- When there is a potential problem
- When the valve is fully open
- When the valve is fully close

For the setting method refer to < **AL1 URGT** > and < **AL2 URGT** > of page 47.

6 Calibration

6.1 Description of Display

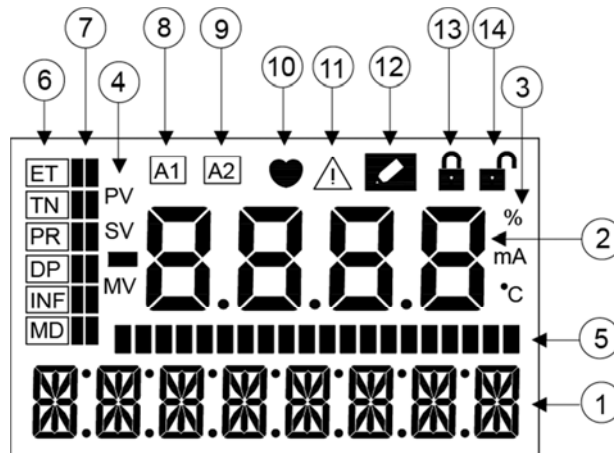

No.	Displayed contents	Description	
①	Manu information	Displays the running menu. (Main menu, Main parameter, Sub parameter)	
②	Manu's value	Displays the currently parameter value of the menu.	
③	Manu's value unit	Displays the currently menu's value unit.	
④	Menu's value separator	PV	Progress value
		SV	Signal value
		MV	Motor control value
⑤	Progress bar	Displays the progress of the processor in bar form.	
⑥	Main parameter	Displays the selected main parameter currently.	
⑦	Parameter bar	Displays the position of the selected main parameter.	
⑧	Alarm 1	The icon is displayed, when the set value of alarm 1 is satisfied.	
⑨	Alarm 2	The icon is displayed, when the set value of alarm 2 is satisfied.	
⑩	HART communication	The icon is displayed, when HART communication is in progress.	
⑪	Error code	The icon is displayed If there is an error during calibration or operation.	
⑫	Modifying	The icon is displayed, when changing the internal setting values such as parameter modification.	
⑬	LOCK	The icon is displayed, when the program is locked.	
⑭	UNLOCK	The icon is displayed, when the program is unlocked.	

6.2 Description of Buttons

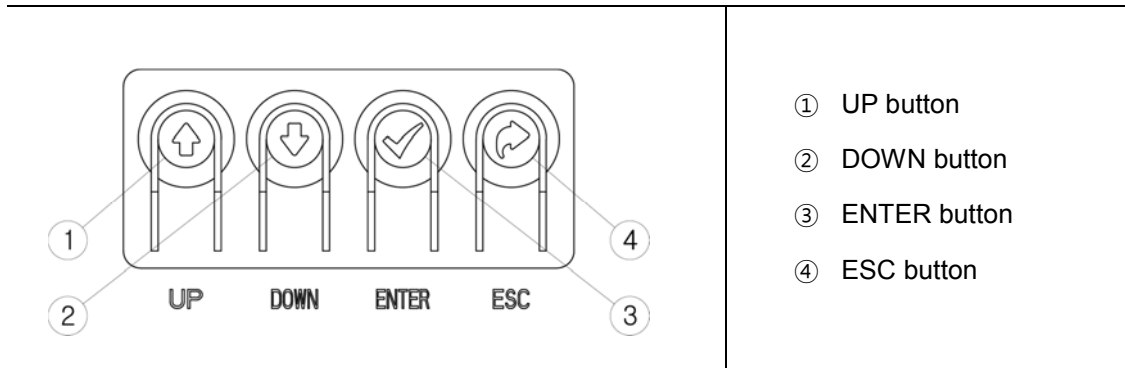

Button	Descriptions
ENTER	<ul style="list-style-type: none"> • Execute the functions of the selected menu. • Saving the modified parameter values.
ESC	<ul style="list-style-type: none"> • Moving from the current menu go back to the upper level menu. • Cancel current command.
UP	<ul style="list-style-type: none"> • Moving between menus of the same level such as main menu, main parameter, sub parameter. • Change to the larger value of the set value of the selected parameter.
DOWN	<ul style="list-style-type: none"> • Moving between menus of the same level such as main menu, main parameter, sub parameter. • Change to the smaller value of the set value of the selected parameter.

6.3 How to perform the fast auto calibration

Open the cover of the product follow below steps to perform the quick auto calibration.

- ① Input 4~20mA of current signal, pressing the <ENTER> button for 3seconds.
 - ② When "TUNNIG" is displayed, press the <ENTER> button once.
 - ③ When "AUTO RUN" is displayed, press the<ENTER> button once, and then starts the auto calibration.
 - ④ The calibration process may take 1 ~ 3 minutes depending on the valve size.
-

6.3.1 Steps of auto calibration

When auto calibration is progress, it will proceed automatically in the following steps.

Steps	Check point
STEP0	Check the zero point of the valve speed. checked at the reference point of valve stops.
STEP1	Finding a zero point of the valve stroke.
STEP2	Finding a end point of the valve stroke.
STEP3	Measure the time of valve fully open. Measure the time of the valve takes from full close to full open.
STEP4	Measure the time of valve fully close. Measure the time of the valve takes from full open to full close.
STEP5	Measure of the Low BIAS Measure the motor signal reference value, when the position of valve at the 25%.
STEP6	Measure of the High BIAS Measure the motor signal reference value, when the position of valve at the 75%.

6.4 Software map

TS800 SOFTWARE MAP (V.1.1.0)

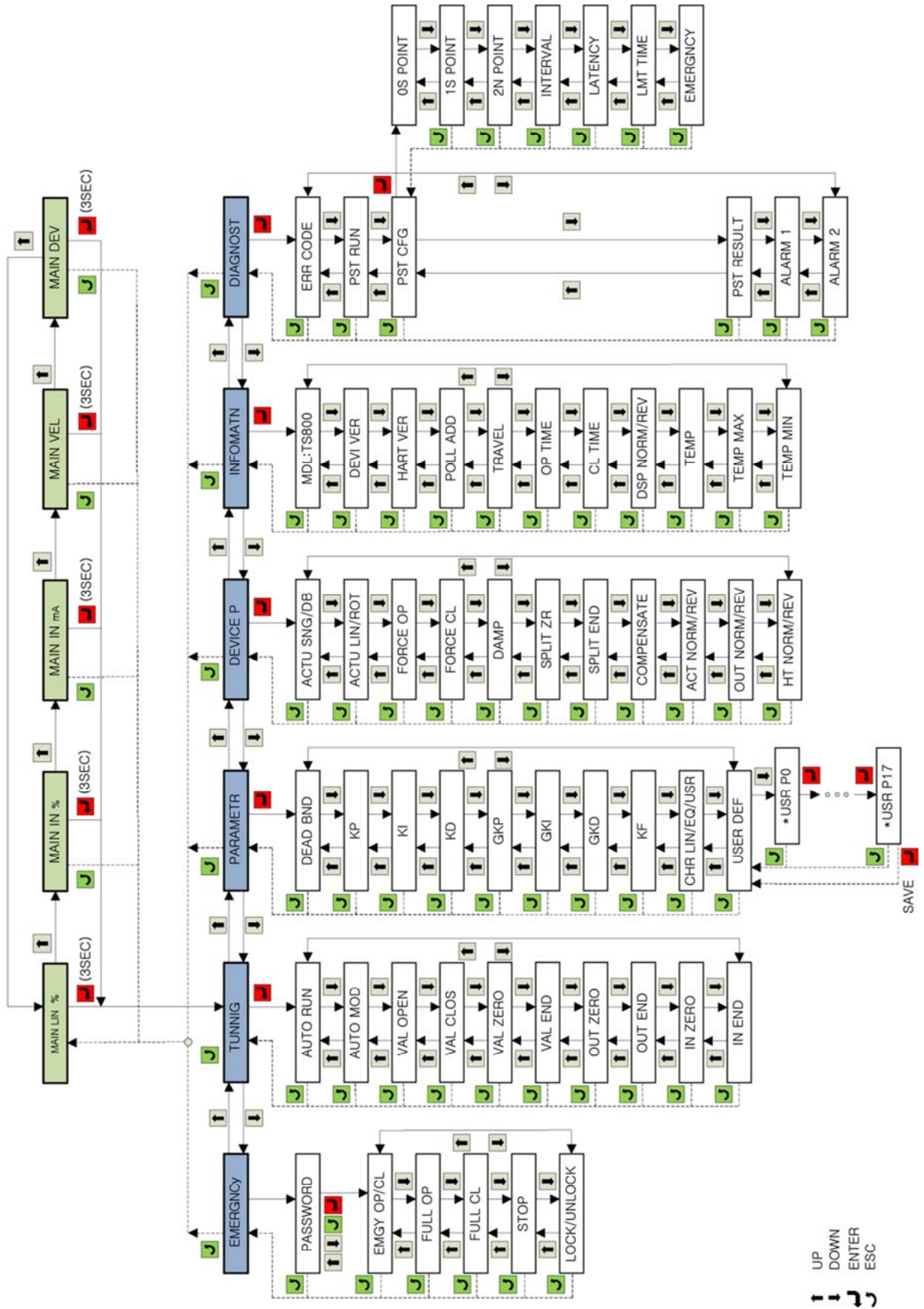

6.5 Description of Main menus

When the product is booted, **<MAIN LIN>** is displayed, which shows the current opening of the valve. Press **<UP>** or **<DOWN>** button to move to the following menu and check the corresponding information.

In the main menu, information such as the valve opening and the magnitude of the input current signal can be checked and the execution of the command or the modification of the parameter value cannot be performed.

Main menus	Description	
MAIN LIN	Displayed percentage of current valve opening value Depending on the set value of the flow characteristics, one of the following 5 is displayed.	
	LCD display value	
	Set flow characteristics	
	MAIN LIN	Linear
	MAIN EQ1	EQ1 (1/25)
	MAIN EQ2	EQ2 (1/50)
	MAIN QO	Quick Open
MAIN USR	User defined 17 points	
MAIN IN %	Displayed the magnitude of input signal that the positioner recognizes as percentage. <ul style="list-style-type: none"> If the size of the input signal recognized by the positioner differs from output signal of the DCS or calibrator, check the voltage of the power supply. If the supply current is normal, please reset the <IN ZERO> and <IN END> values in the <TUNNING> of main parameter. 	
MAIN IN mA	Displayed the magnitude of input signal that the positioner recognizes as mA. <ul style="list-style-type: none"> If the size of the input signal recognized by the positioner differs from output signal of the DCS or calibrator, check the voltage of the power supply. If the supply current is normal, please reset the <IN ZERO> and <IN END> values in the <TUNNING> of main parameter. 	
MAIN VEL	Displayed currently operating speed of the valve as numbers. <ul style="list-style-type: none"> The numbers between -2047 to +2048 and negative numbers indicate speed at close, and positive numbers indicate speed at open. 0 means stop and the larger the absolute value, the faster the speed. 	
MAIN DEV %	Displayed current input signal and valve opening value as percentage. <ul style="list-style-type: none"> Display percentage of error between the current input signal and valve opening value. The larger the error, the lower the control characteristic. 	

6.6 Description of Main parameters

The main parameter menu corresponds to the main menu in which various parameters are classified by function.

- When the product is booted, press and hold the **<ENTER>** button for 3 seconds to enter the main menus.
- Main menu is classified as below and can be moved by pressing **<UP>** or **<DOWN>** buttons.
- Press the **<ENTER>** button in the corresponding main menu to enter the sub parameter menus.

Main menus	Main functions of Submenu
TUNING	<ul style="list-style-type: none"> • Auto calibration. • Change position of valve zero and span manually. • Change the zero and span of feedback signal manually.
PARAMETR	<ul style="list-style-type: none"> • Setting the Dead band. • Change PID values. • Change the flow characteristics.
DEVICE P	<ul style="list-style-type: none"> • Setting the Single and Double, according to the actuator types. • Setting the Linear and Rotary, according to the actuator types. • Setting the signal point of Force Open/Close. • Setting the acting type of Direct action/ Reverse action. • Change the valve acting speed.
INFOMATN	<ul style="list-style-type: none"> • Display the model of product. • Display the versions of device and HART. • Display the accumulated time of Open/Close. • Display the current ambient temperature, the recorded maximum ambient temperature, and the recorded minimum ambient temperature.
DIAGNOST	<ul style="list-style-type: none"> • Display the error code. • Setting the PST function. • Setting the Alarm function.
EMERGNcy	<ul style="list-style-type: none"> • In case of emergency, set to forcibly open the valve, or close valve, or maintain current position of the function. • Setting the Lock and Unlock function.





6.7 Description of Submenus

The following is detailed description about the corresponding submenu of the main menu.

- Press <ENTER> button in the main menu to enter the submenus.
- Use <UP> and <DOWN> buttons to move between submenus.

6.7.1 Submenus of TUNNING

Submenus	Description of function	
AUTO RUN	Perform auto calibration <ul style="list-style-type: none"> • Executable from any input signal between 4 and 20 mA. • It takes 1~3minutes, depending on the valve size. 	
AUTO MOD	Selects the auto calibration mode. It is set to normal mode at the factory.	
	Selectable value	Description
	AM FULL	Set all parameter values again.
	AM BIAS	Only reset the motor reference value, but the other parameter values are not modified.
	AM PIDb	Only reset PID value, but the other parameter values are not modified.
	AM ZEb R	Only reset End point and Zero point of the valve, but the other parameter values are not modified.
	Factory setting AM FULL	
VAL OP/CL	Regardless of the current signal, it performs the function of opening and closing the valve with the <UP> or <DOWN> buttons manually.	
VAL ZERO	Reset the ZERO point of the valve manually. Input 4mA current, press the <UP> and <DOWN> button to change the valve position, and press the <ENTER>button to save the current valve position, then the positioner recognizes the current position as the valve ZERO point.	
VAL END	Reset the END point of the valve manually. Input 20mA current, press the <UP> and <DOWN> button to change the valve position, and press the <ENTER>button to save the current valve position, then the positioner recognizes the current position as the valve END point.	



OUT ZERO	Reset the ZERO point of the feedback signal manually. Input 4mA current signal, valve reaches zero position, after press the <UP> or <DOWN> button to adjust the value, until the 4mA feedback signal is output, and then press the <ENTER> button to save.
	 NOTICE
	OUT ZERO setting must be done once after installing feedback module
OUT END	Reset the END point of the feedback signal manually. Input 20mA current signal, valve reaches end position, after press the <UP> or <DOWN> button to adjust the value, until the 20mA feedback signal is output, and then press the <ENTER> button to save.
	 NOTICE
	OUT END setting must be done once after installing feedback module
IN ZERO	Reset the ZERO value of input signal manually.. If <MAIN IN%> and <MAIN mA> appear in the main menu differ from the actual input signal, execute the commands in this menu. Input 4mA current from this menu and press <ENTER> button to save.
	 NOTICE
	After replacing the main board or After program initialization, you must set the IN ZERO setting once.
IN END	Reset the END value of input signal manually. If <MAIN IN%> and <MAIN mA> that appear in the main menu differ from the actual input signal, execute the commands of this menu. Input 20mA current from this menu and press <ENTER> button to save.
	 NOTICE
	After replacing the main board or After program initialization, you must set the IN END setting once.
BIAS25	The reference value of the motor whose valve stroke is 25% It is set automatically at auto-calibration, please do not modify this parameter value manually.
BIAS75	The reference value of the motor whose valve stroke is 75% It is set automatically at auto-calibration, please do not modify this parameter value manually.

6.7.2 Submenus of PARAMETR

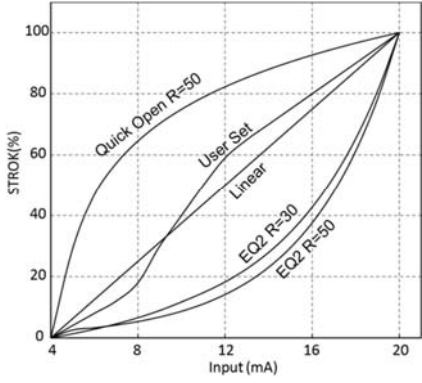
Submenus	Description	
DEAD bND	<p>Dead band range, the range of allowable control error.</p> <ul style="list-style-type: none"> If hunting or oscillation occurs due to high packing friction of the valve, the problem can be solved by increasing the value within the range allowed by the field. If the value is set too high, the accuracy may be reduced. 	
	Range of settable value	0~100%
	Factory setting	0.3%
KP	<p>P control value, the proportionality constant value of the control signal in the process of reaching the target point</p> <ul style="list-style-type: none"> If the setting value increase, the positioner finds the target point quickly but it is more likely to have hunting. If the setting value decrease, the stability of the positioner is higher, but positioner finds the target point slowly. 	
	Range of settable value	0~500.0
KI	<p>I control value, the integral value that adds the correction signal according to the error percentage to the existing correction signal.</p> <ul style="list-style-type: none"> If the setting value is too high, the time to reach the target point is accelerated, but the oscillation phenomenon is easy to occur. If the setting value is too low, it will slow down the search for the target point. 	
	Range of settable value	0~500.0
KD	<p>D control value, indicates the derivative value of the compensation signal based on the percentage of error allowance.</p> <ul style="list-style-type: none"> If the setting value is too high, it will slow down the search for the target point. If the setting is too low, the oscillation is likely to occur. 	
	Range of settable value	0~500.0
GKP	<p>P control value, the proportionality constant value of the control signal in the process of reaching the target point</p> <ul style="list-style-type: none"> The function is the same as the KP control value but falls within the $\pm 1\%$ error range of the target value, the GKP value is applied instead of the KP value. 	
	Range of settable value	0~500.0
GKI	<p>I control value, the integral value that adds the correction signal according to the error percentage to the existing correction signal.</p> <ul style="list-style-type: none"> The function is the same as the KI control value but falls within the $\pm 1\%$ error range of the target value, the GKI value is applied instead of the KI value. 	
	Range of settable value	0~500.0
GKD	<p>D control value, indicates the derivative value of the compensation signal based on the percentage of error allowance.</p> <ul style="list-style-type: none"> The function is the same as the KD control value but falls within the $\pm 1\%$ error range of the target value, the GKD value is applied instead of the KD value. 	
	Range of settable value	0~500.0

KF	Control value to overcome valve friction. <ul style="list-style-type: none"> Increasing the KF value can improve hunting that is caused by valve friction. 																																																																																																													
	Range of settable value	0~500.0																																																																																																												
	Factory setting	0																																																																																																												
CHAR	Set the characteristics of the valve control.																																																																																																													
																																																																																																														
	<table border="1" data-bbox="893 548 1396 1108"> <thead> <tr> <th>Input (mA)</th> <th>Linear (%)</th> <th>EQ1 (%)</th> <th>EQ2 (%)</th> <th>QO (%)</th> <th>USER (%)</th> </tr> </thead> <tbody> <tr><td>4</td><td>0</td><td>0</td><td>0</td><td>0</td><td>0</td></tr> <tr><td>5</td><td>6.25</td><td>2.55</td><td>1.31</td><td>29.13</td><td>4</td></tr> <tr><td>6</td><td>12.5</td><td>3.26</td><td>2.81</td><td>46.84</td><td>8</td></tr> <tr><td>7</td><td>18.75</td><td>4.16</td><td>4.54</td><td>57.21</td><td>12</td></tr> <tr><td>8</td><td>25</td><td>5.32</td><td>6.55</td><td>64.56</td><td>18</td></tr> <tr><td>9</td><td>31.25</td><td>6.79</td><td>8.92</td><td>70.27</td><td>30</td></tr> <tr><td>10</td><td>37.5</td><td>8.67</td><td>11.73</td><td>74.93</td><td>40</td></tr> <tr><td>11</td><td>43.75</td><td>11.07</td><td>14.76</td><td>78.87</td><td>50</td></tr> <tr><td>12</td><td>50</td><td>14.14</td><td>18.26</td><td>82.28</td><td>59</td></tr> <tr><td>13</td><td>56.25</td><td>18.06</td><td>22.58</td><td>85.29</td><td>65</td></tr> <tr><td>14</td><td>62.5</td><td>23.06</td><td>27.93</td><td>87.99</td><td>70</td></tr> <tr><td>15</td><td>68.75</td><td>29.45</td><td>34.55</td><td>90.42</td><td>75</td></tr> <tr><td>16</td><td>75</td><td>37.61</td><td>42.73</td><td>92.65</td><td>80</td></tr> <tr><td>17</td><td>81.25</td><td>48.02</td><td>52.85</td><td>94.69</td><td>85</td></tr> <tr><td>18</td><td>87.5</td><td>61.32</td><td>65.37</td><td>96.59</td><td>90</td></tr> <tr><td>19</td><td>93.75</td><td>78.31</td><td>80.85</td><td>98.35</td><td>95</td></tr> <tr><td>20</td><td>100</td><td>100</td><td>100</td><td>100</td><td>100</td></tr> </tbody> </table>		Input (mA)	Linear (%)	EQ1 (%)	EQ2 (%)	QO (%)	USER (%)	4	0	0	0	0	0	5	6.25	2.55	1.31	29.13	4	6	12.5	3.26	2.81	46.84	8	7	18.75	4.16	4.54	57.21	12	8	25	5.32	6.55	64.56	18	9	31.25	6.79	8.92	70.27	30	10	37.5	8.67	11.73	74.93	40	11	43.75	11.07	14.76	78.87	50	12	50	14.14	18.26	82.28	59	13	56.25	18.06	22.58	85.29	65	14	62.5	23.06	27.93	87.99	70	15	68.75	29.45	34.55	90.42	75	16	75	37.61	42.73	92.65	80	17	81.25	48.02	52.85	94.69	85	18	87.5	61.32	65.37	96.59	90	19	93.75	78.31	80.85	98.35	95	20	100	100	100	100	100
	Input (mA)	Linear (%)	EQ1 (%)	EQ2 (%)	QO (%)	USER (%)																																																																																																								
	4	0	0	0	0	0																																																																																																								
	5	6.25	2.55	1.31	29.13	4																																																																																																								
6	12.5	3.26	2.81	46.84	8																																																																																																									
7	18.75	4.16	4.54	57.21	12																																																																																																									
8	25	5.32	6.55	64.56	18																																																																																																									
9	31.25	6.79	8.92	70.27	30																																																																																																									
10	37.5	8.67	11.73	74.93	40																																																																																																									
11	43.75	11.07	14.76	78.87	50																																																																																																									
12	50	14.14	18.26	82.28	59																																																																																																									
13	56.25	18.06	22.58	85.29	65																																																																																																									
14	62.5	23.06	27.93	87.99	70																																																																																																									
15	68.75	29.45	34.55	90.42	75																																																																																																									
16	75	37.61	42.73	92.65	80																																																																																																									
17	81.25	48.02	52.85	94.69	85																																																																																																									
18	87.5	61.32	65.37	96.59	90																																																																																																									
19	93.75	78.31	80.85	98.35	95																																																																																																									
20	100	100	100	100	100																																																																																																									
Possible values	CHAR LIN	Linear																																																																																																												
	CHAR EQ1	Equal percentage (1/25)																																																																																																												
	CHAR EQ2	Equal percentage (1/50)																																																																																																												
	CHAR QUI	Quick Open																																																																																																												
	CHAR USR	User defined 17 points																																																																																																												
Factory setting	CHAR LIN																																																																																																													
USER DEF	Realize the special flow curve by user-defined 17 points. <ul style="list-style-type: none"> In addition to the above Linear, Equal percentage, Quick open and other typical flow characteristics, the user can set the 4~20mA corresponding valve stroke position to achieve special flow curve control. To execute this function, <CHAR USR> must be set from the <CHAR> menus above. 																																																																																																													
	Setting steps	Set the valve position according to the signal.																																																																																																												
	*USR P0	Set the valve position when the input signal is 4 mA.																																																																																																												
	*USE P1	Set the valve position when the input signal is 5 mA.																																																																																																												
	*USR P2	Set the valve position when the input signal is 6 mA.																																																																																																												
	*USR P3~16	Follow above steps for setting the valve position when the input signal is 7~19mA .																																																																																																												
*USR P17	Set the valve position when the input signal is 20 mA.																																																																																																													

6.7.3 Submenus of DEVICE P

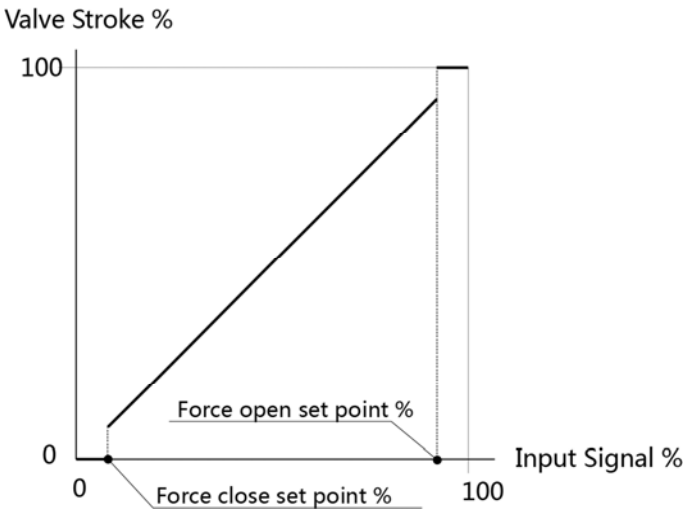
Submenus	Description		
ACTU SNG	Depending on the actuator type, it must be set to Single or Double manually.		
	 NOTICE		
	If the set value differs from the actuator type, the control characteristic may be degraded.		
	Possible settings	ACTU SNG	Single type
		ACTU DbL	Double type
Factory setting	TS800L	ACTU SNG	
	TS800R	ACTU DbL	
ACTU LIN	Depending on the actuator type, it must be set to Single or Double manually.		
	 NOTICE		
	If the set value differs from the actuator type, the control characteristic may be degraded.		
	Possible settings	ACTU LIN	Linear type
		ACTU ROT	Rotary type
Factory setting	TS800L	ACTU LIN	
	TS800R	ACTU ROT	
FORCE OP	<p>When the input signal is higher than the set value, the valve is forced to open. This parameter is used to move the valve into its seat with the maximum force of the actuator.</p>  <p>The graph shows Valve Stroke % on the y-axis (0 to 100) and Input Signal % on the x-axis (0 to 100). A solid line starts at the origin (0,0) and rises linearly to (100,100). A vertical dashed line at approximately 80% on the x-axis is labeled 'Force open set point %'. A horizontal dashed line at 0% on the y-axis is labeled 'Force close set point %'.</p>		
	Range of settable values	0~100%	
	Factory setting	100%	
	Note	When the value set to 100%, this function is not applied.	

FORCE CL	When the input current signal is lower than the set value, the valve is forced to close. <ul style="list-style-type: none"> When the valve is closed, residual pressure in the actuator chamber can be completely released. 	
	Range of settable values	0~100%
	Factory setting	0.3%
	Note	When the value set to 0%, this function is not applied.
DAMP	This function controls the operating speed of the valve. <ul style="list-style-type: none"> The higher the set value, the slower the operating speed of the valve. With this function, hunting phenomenon of small actuator can be solved. 	
	Range of settable values	0~100%
	Factory setting	0%
	Note	When the value set to 0%, this function is not applied.
SPLIT ZR	Set the zero point of the signal value during the split range control. For example, if the set value is 50%, 12mA corresponds to 0% of the valve opening as shown in the right figure .	
	Range of settable values	0~100%
	Factory setting :	0%
SPLIT END	Set the end point of the signal value during the split range control. For example, if the set value is 50%, 12mA corresponds to 100% of the valve opening as shown in the right figure .	
	Range of settable values	0~100%
	Factory setting :	0%

**Smart valve positioner
TS800 Series**

	This parameter corrects the error between LCD value and actual valve opening.		
	⚠ NOTICE		
COMPENSA	This function should only be used with Linear type products and rotary products must be set to 0%.		
	Range of setting values	0~100%	
	Factory setting	TS800L(Linear type)	2%
		TS800R(Rotary type)	0%
	Change the action type of the valve.		
	Reverse Action		Direct Action
ACT NORM			
	Possible settings	ACT NORM	Reverse Action
		ACT REVE	Direct Action
	Factory setting	ACT NORM	
	Set the feedback signal from the positioner can be output at the same percentage as the valve stroke, or the opposite percentage.		
	Normal		Reverse
OUT NORM			
	Possible settings	OUT NORM	Normal action
		OUR REVE	Reverse action
	Factory setting	OUT NORM	
	Adjusts the valve opening in the forward reverse or direction of the HART communication signal.		
HT NORM	Possible settings	HT NORM	Direct action
		HT REVE	Reverse action
	Factory setting	HT NORM	

6.7.4 Submenus of INFOMATN

You can find the following information through the submenus.

Submenus	Description	
MDL	Displays the model of the product.	
DEVI VER	Displays the version of device.	
HART VER	Displays the version of HART communication.	
POLL ADD	Displays the polling address of the device in HART communication.	
TRAVEL	<p>Displays the accumulated total travel distance of the valve after the positioner has been used. (Unit: K%)</p> <p>One full travel distance from full close to full open means 100% = 0.001K% For example, if the travel value is 1K%, this means that the valve has moved 1000 stroke percentages.</p>	
OP TIME	<p>Displays the total accumulated time when the valve is fully open.</p> <p>Unit : Second</p>	
CL TIME	<p>Displays the total accumulated time when the valve is fully close.</p> <p>Unit : Second</p>	
DSP NORM	Display the valve opening value on the LCD in reverse direction.	
	Possible settings	DSP NORM When the valve position is 0%, 0% is displayed on the LCD. When the valve position is 100%, 100% is displayed on the LCD.
		DSP REVE When the valve position is 0%, 100% is displayed on the LCD. When the valve position is 100%, 0% is displayed on the LCD.
Factory setting	DSP NORM	
TEMPERAT	Check the current ambient temperature of the positioner through the built-in temperature sensor.	
TEMP MAX	Displays the recorded lowest ambient temperature value after using the product.	
TEMP MIN	Displays the recorded lowest ambient temperature value after using the product.	

6.7.5 Submenus of DIAGNOST

Submenus	Description		
ERR CODE	Displays the error code of the product. You can check the error code to resolve the problem. For details, refer to the explanation of error codes.(Page 49)		
PST RUN	Set whether to execute the PST function.		
	What is PST	Partial stroke testing (or PST), within the range of not affecting to the flow process, PST prevents the valve stem from sticking by moving the valve finely according to the set value and the period. In case of emergency, it can make the valve operate normally.	
	Possible settings	PST RUN	Execute the PST function
		PST OFF	Do not execute PST function
Factory setting	PST OFF		
PST CFG	Set the necessary items to execute the PST function. The submenu of PST CFG is as below.		
Submenu	Description		
OP POINT	Sets start position when PST is supposed to start. Valve initial position must be within $\pm 1\%$ from " OS POINT ". If not, wait until this condition is satisfied.		
	Default value	100%	
	Range of values	0~100%	
1S POINT	Sets 1st target position of PST.		
	Default value	90%	
	Range of values	0~100%	

	2N POINT	Sets 2nd target position of PST.	
		Default value	80%
		Range of values	0~100%
	INTERVAL	Set the waiting time after the first PST is performed and the second PST start.	
		Default value	20 (Seconds)
		Range of values	1~100 (Seconds)
	LATENCY	Set the waiting time from "1S POINT" to "2N POINT" start. After reaching the first target point "1S POINT", return to the initial position, wait for the "LATENCY" time specified by the user, and then move to the second "2S POINT" target point again.	
		Default value	10 (Seconds)
		Range of values	1~100 (Seconds)
	LMT TIME	Set the time allowed to reach the target point. If the time to reach the target value during the PST execution exceeds the "LMT TIME" time or there is no movement, the PST is considered to have failed and the PST is immediately interrupted.	
		Default value	5 (Seconds)
		Range of values	0~100 (Seconds)
	EMERGENCY	In the PST process, if the valve position exceeds the "EMERGENCY" set value, the PST function is stopped	
		Default value	15%
		Range of values	0~100%
PST REDy	Check the PST function execution result value. The LCD screen displays the following information based on the set values and the execution results. See the table below to confirm the PST execution result information.		
	Result value	PST REDy	Ready to run PST.
		PST SUCS	PST succeed.
		PST TOUT	"LMT TIME" failed to reach the target value within the set time value range.
		PST FIXD	Valve has no action.
		PST DOUT	Exceed the target value by more than 1%.
		PST EMRG	Exceeding the allowable valve position error range, beyond the "EMERGENCY" setting value.

AL1 URGT	<p>Setting Alarm 1 According to the set value, If the following conditions are satisfied, the alarm circuit is turned “ON”, and LCD displayed A1 symbol. It remains “OFF” during normal operation.</p>		
	Possible settings	AL1 URGT	When the product has a serious problem When the priority value is 0 in the error code. (Refer to page 48)
		AL1 PRI 1	When there is a potential problem When the product has a serious problem When the priority value is 1 in the error code. (Refer to page 48)
		AL1 F_CL	When the valve is fully closed.
		AL1 F_OP	When the valve is fully opened.
AL1 NONE		Disable this alarm function	
Factory setting	AL1 URGT		
AL2 URGT	<p>Setting Alarm 2 According to the set value, If the following conditions are satisfied, the alarm circuit is turned “ON”, and LCD displayed A2 symbol. It remains “OFF” during normal operation.</p>		
	Possible settings	Same as AL1 URGT of above	
	Factory setting	AL2 URGT	

6.7.6 Submenus of EMERGNcy

Submenus	Description		
PASSWORD	Must enter a password to enter this menu. The password is set at the factory and cannot be changed by the user.		
	Factory setting	Press UP > ENTER > DOWN > UP button sequentially. (Press the 1321 buttons from left to right)	
EMGY OP	The position of the valve to be moved can be determined when an abnormality of the positioner is detected.		
	Possible settings	EMGy None	Do not take any action.
		EMGy Open	Open the valve fully.
		EMGy Close	Close the valve fully.
		EMGy Stop	Stop the valve operation.
Factory setting	EMGy None		
FULL OP	Open the valve fully by manual regardless of the input signal.		
FULL CL	Close the valve fully by manual regardless of the input signal.		
STOP	Maintains the current valve position regardless of the input signal.		
LOCK or UNLOCK	It locks to prevent changing all parameter values. When set to " LOCK ", all commands such as auto-calibration, PID change, and set parameter values cannot be changed.		
	Passible setting	LOCK	Lock the program
		UNLOCK	Unlock the program
Factory setting	UNLOCK		

7 Error code and Troubleshooting

- If there is a problem when installing or using the product, the  symbol appears on the top of the LCD.
- If you enter the “**ERR CODE**” which is submenu of “**DIAGNOST**”, an error code appears.
- Check the error code and refer to the table below to solve the problem.

No	Code	priority	Cause	Resolution
1	L	1	Valve End point is set too high	<ul style="list-style-type: none"> • Check whether the positioner is installed too high or low. • Check whether the positioner is installed too far from the actuator. (Check the angle of use) • Check the potentiometer gear and main gear are out of position. (The cause of the problem is strong vibration or external shock).
2	K	1	Valve Zero point is set too low	<ul style="list-style-type: none"> • Check whether the positioner is installed too high or low. • Check whether the positioner is installed too far from the actuator. (Check the angle of use) • Check the potentiometer gear and main gear are out of position. (The cause of the problem is strong vibration or external shock).
3	J	1	Valve End and Zero points are set too close. (Use angle is too small)	<ul style="list-style-type: none"> • Increase the angle of use by repositioning the positioner closer to the actuator.
4	I	1	Input current is below 3.8mA	<ul style="list-style-type: none"> • Check input current signal
5	H	1	Input current is over 22mA	<ul style="list-style-type: none"> • Check input current signal
6	G	1	BIAS value exceeds limit	<ul style="list-style-type: none"> • Run Auto-Calibration again (Accuracy is significantly reduced when used without auto-calibration)
7	F	1	Ambient temperature too high	<ul style="list-style-type: none"> • Check ambient temperature
8	E	1	Ambient temperature too low	<ul style="list-style-type: none"> • Check ambient temperature
9	D	1	Used over 100,000 cycles	<ul style="list-style-type: none"> • Check positioner regularly
10	C	0	Used over 500,000 cycles	<ul style="list-style-type: none"> • Check positioner regularly
11	B	0	Used over 1million cycles	<ul style="list-style-type: none"> • Replace positioner
12	A	0	EEPROM damaged	<ul style="list-style-type: none"> • Replace main PCB

8 Limited warranty and disclaimer

- This product has been fully inspected and shipped through a thorough quality inspection procedure. The manufacturer warranty period of the product is 18 months after the product is shipped from Tissin in Korea.
- For any failure or damage reported within the warranty period which is clearly our responsibility, a replacement product or necessary parts will be provided. This limited warranty applies only to our product independently, and not to any other damage incurred due to the failure of the product.
- Using the device in a manner that does not fall within the scope of its intended use, disregarding this manual, using under qualified personnel, or making unauthorized alterations releases the manufacturer from liability for any resulting damage. This renders the manufacturer's warranty null and void.

Note

Smart valve positioner TS800 Series

Архангельск (8182)63-90-72
Астана (7172)727-132
Астрахань (8512)99-46-04
Барнаул (3852)73-04-60
Белгород (4722)40-23-64
Брянск (4832)59-03-52
Владивосток (423)249-28-31
Волгоград (844)278-03-48
Вологда (8172)26-41-59
Воронеж (473)204-51-73
Екатеринбург (343)384-55-89

Иваново (4932)77-34-06
Ижевск (3412)26-03-58
Иркутск (395)279-98-46
Казань (843)206-01-48
Калининград (4012)72-03-81
Калуга (4842)92-23-67
Кемерово (3842)65-04-62
Киров (8332)68-02-04
Краснодар (861)203-40-90
Красноярск (391)204-63-61
Курск (4712)77-13-04
Липецк (4742)52-20-81

Магнитогорск (3519)55-03-13
Москва (495)268-04-70
Мурманск (8152)59-64-93
Набережные Челны (8552)20-53-41
Нижний Новгород (831)429-08-12
Новокузнецк (3843)20-46-81
Новосибирск (383)227-86-73
Омск (3812)21-46-40
Орел (4862)44-53-42
Оренбург (3532)37-68-04
Пенза (8412)22-31-16

Пермь (342)205-81-47
Ростов-на-Дону (863)308-18-15
Рязань (4912)46-61-64
Самара (846)206-03-16
Санкт-Петербург (812)309-46-40
Саратов (845)249-38-78
Севастополь (8692)22-31-93
Симферополь (3652)67-13-56
Смоленск (4812)29-41-54
Сочи (862)225-72-31
Ставрополь (8652)20-65-13

Сургут (3462)77-98-35
Тверь (4822)63-31-35
Томск (3822)98-41-53
Тула (4872)74-02-29
Тюмень (3452)66-21-18
Ульяновск (8422)24-23-59
Уфа (347)229-48-12
Хабаровск (4212)92-98-04
Челябинск (351)202-03-61
Череповец (8202)49-02-64
Ярославль (4852)69-52-93

Киргизия (996)312-96-26-47 Казахстан (772)734-952-31 Таджикистан (992)427-82-92-69

<http://tissin.nt-rt.ru/> || tni@nt-rt.ru